



Tarım Bilimleri Dergisi
Tar. Bil. Der.

Dergi web sayfası:
www.agri.ankara.edu.tr/dergi

Journal of Agricultural Sciences

Journal homepage:
www.agri.ankara.edu.tr/journal

Influence of Seed Physical Properties and Speed on the External Mechanical Damage Index and In-Row Spacing Uniformity in an Automatic Potato Planter

Mustafa Gökcalp BOYDAŞ^a

Fatih UYGAN^a

^a Atatürk University, Faculty of Agriculture, Department of Agricultural Machinery, Erzurum, TURKEY

ARTICLE INFO

Research Article — Agricultural Technologies

Corresponding author: Mustafa Gökcalp BOYDAŞ, e-mail: mboydas@atauni.edu.tr, Tel: +90(442) 231 25 49

Received: 26 January 2012, Received in revised form: 13 July 2012, Accepted: 10 December 2012

ABSTRACT

In this study, a new fully automatic potato planter was used in which the planting metering mechanism consists of cups and hold pins attached to the circumference of a vertical disc. In order to evaluate performance of the planting metering mechanism, in-row spacing uniformity and external mechanical damage index were determined ($P<0.01$). Also skips and doubles that caused deterioration of in-row spacing uniformity were investigated. In experiment, two potato varieties (Marfona and Agria) and two potato sizes (25-45 and 45-65 mm) were used. The ground speeds of potato planter were chosen as 3.5, 5.4 and 7.3 km h⁻¹. The results obtained from the experiment indicated that the ground speeds and tuber physical properties significantly influenced tuber spacing accuracy and external mechanical damage index ($P<0.01$). While the ground speed increased, accuracy of tuber spacing decreased. The highest coefficient of variation (CV%) values were obtained from ground speed of 7.3 km h⁻¹, Marfona variety, and tubers between 25-45 mm, with 26.80%, 25.58% and 26.27%, respectively. The highest damage index values were obtained from ground speed of 7.3 km h⁻¹, Agria variety, and tubers between 45-65 mm, with 1.34, 1.18 and 1.23, respectively.

Keywords: Potato planter; Metering mechanism; Spacing uniformity; External mechanical damage index

Tam Otomatik Bir Patates Dikim Makinasında Tohum Fiziksel Özelliklerinin ve Makina İlerleme Hızının Sıra Üzeri Tohum Dağılım Düzgünlüğü ve Yumru Zedelenme İndeksi Üzerine Etkisi

ESER BİLGİSİ

Araştırma Makalesi—Tarım Teknolojileri

Sorumlu Yazar: Mustafa Gökcalp BOYDAŞ, e-posta: mboydas@atauni.edu.tr, Tel: +90(442) 231 25 49

Geliş tarihi: 26 Ocak 2011, Düzeltmelerin gelişi: 13 Temmuz 2012, Kabul: 10 Aralık 2012

ÖZET

Bu çalışmada, dikey bir disk etrafına belirli aralıklarla dizilmiş keççe ve tutucu çubuklardan oluşan tohum dağıtma düzenine sahip yeni bir tam otomatik patates dikim makinası kullanıldı. Tohum dağıtma düzeninin performansını değerlendirmek için sıra üzeri tohum dağılım düzgünlüğü ve yumru zedelenme indeksi belirlendi. Ayrıca sıra üzeri dağılım düzgünlüğünün bozulmasına sebep olan boşluk ve ikizlenme incelendi. Denemelerde iki farklı patates çeşidi (Marfona and Agria) ve iki farklı patates boyutu (25-45 ve 45-65 mm) kullanıldı. Patates dikim makinası ilerleme hızları 3.5, 5.4 ve 7.3 km h⁻¹ olarak seçildi. Yumru fiziksel özelliklerinin ve makina ilerleme hızının sıra üzeri tohum dağılım düzgünlüğünü ve zedelenme indeksini önemli derecede etkilediği belirlendi ($P<0.01$). İlerleme hızının artmasıyla sıra üzeri tohum dağılım düzgünlüğü bozuldu ve en yüksek varyasyon katsayısı (%VK)

değerleri 7.3 km h⁻¹ ilerleme hızı için %26.80, Marfona için %25.58 ve 25-45 mm aralığındaki tohumlar için %26.27 olarak bulundu. En yüksek zedelenme indeks değerleri 7.3 km h⁻¹ ilerleme hızı için 1.34, Agria için 1.18 ve 45-65 mm aralığındaki yumrular için 1.23 olarak bulundu.

Anahtar Kelimeler: Patates dikim makinası; Dağıtma düzeni; Sıra üzeri düzgünlük; Mekanik zedelenme indeksi

© Ankara Üniversitesi Ziraat Fakültesi

1. Introduction

Potato which is a versatile, carbohydrate-rich food and highly popular worldwide has an important place among plants cultivated in the world. Potato is consumed as a vegetable as well as processed. Potato is grown in more than 100 countries, under temperate, subtropical and tropical conditions (Potato 2008). The potato crop is usually grown not from seed but from "seed potatoes". To fulfil the food demand of an increasing population, it is necessary to increase yield of the potato which has the ability to produce 2 or 3 times more food material from per unit area when it is compared with cereals (Hussain & Gillani 1985). Planting, cultivating, and harvesting are three main components of potato production. Planting is the first component which has an affect on potato yield. The uniformity of plant density is one of the most important subjects of potato production, so it affects the cost of seed, plant development, yield and quality of potato (Bussan et al 2007; Güllüoğlu & Arioğlu 2009). There are two important factors that effect the plant density of potato planting with machinery. One of those is in-row plant spacing and the other one is inter-row width. Inter-row width largely depends on the tractor's wheel spacing, as well as the machinery used in potato production. Thus, inter-row width of a potato planter is fixed. However, in-row plant spacing plays very important and dynamic roles on potato yield and quality in terms of evaluating the performance of a potato planter (Seyedbagheri 2006). Uniform plant spacing has been suggested to increase potato yield and quality (Klassen 1974; Klassen 1975). Rupp & Thornton (1992) determined that a 10% increase or decrease in plant number from the optimum potato population reduced grower returns from 2% to 12%. In addition, they determined that planter skips and double-clumped seed pieces typically reduced economic return compared with uniform in-row spacing. James et al (1973) studied to estimate the yield losses by removing randomly different percentages of plants from plots at emergence and/or later stages. They determined that the average losses in yield for 10, 20 and 30% misses were 0, 5.6 and 11.1%, respectively. Nevertheless, it is stated by some researchers that the potato is able to compensate for missing plants, judging by reports that the yield reduces about 0.3% for each 1% of plants missing (Hirst et al 1973; James et al 1973).

However, yield alone is not enough to determine the economic worth of potatoes. The size of the tuber also plays a crucial role (Rupp & Thornton 1992). The importance of spacing uniformity is influenced by the size grades that are used to define marketable yield. Therefore, changes in the size of tuber can directly affect grower returns (Schotzko et al 1983; Thornton et al 1983; Rex et al 1987; Rupp & Thornton 1992; Creamer et al 1999; Love & Thompson-Johns 1999). Love & Thompson-Johns (1999) reported that seed pieces of russet-type cultivars planted at 8 cm in-row spacing resulted in higher total tuber yields than seed pieces planted at wider intervals (15 to 91 cm). However, the total yield from the 8 cm spacing treatment returned fewer dollars per ha than those from wider spacing treatments due to a high percentage of undersized tubers. They reported that average tuber weight decreased as seed pieces were planted closer together, and vice versa. Similarly, Rupp & Thornton (1992) and Halderson et al (1992) found an increase in the yield of small undersized tubers from seed pieces that were clumped together versus those spaced farther apart. Siczka (1986) determined that the in-row plant spacing of fields in New York was not uniform, and coefficients of variation (CV %) ranged from 43 to 70% with the average seed placement 4 cm wider than adjusted. Mechanical failure of planters was cited as the primary reason of plant missing. The mechanical failure was presumably due to a combination of factors, which included planting speed, poor planter condition and maintenance.

Capacity and accuracy of plant spacing are the main parameters of machine performance. High accuracy of plant spacing results in a high yield and a uniform sorting of the tubers at harvest (McPhee et al 1996; Pavek & Thornton 2003). The function of the potato planter is to place potatoes singly in furrows at predetermined regular intervals. The spacing is dependent on the efficiency of the feeder. Usually the spacing is done mechanically either by simple hand fed or by relatively more complicated, fully automatic potato planter. One of the most important parts of potato planters is planting metering mechanism. The accuracy of plant spacing is affected by constructional properties of the planting metering mechanism, the planter ground speed, the shape of potato and seed size.

Generally, although the external mechanical damage index is used to determine ability of potato harvesting machines, this can be also used to determine the ability of potato planter. Then it can be said that external mechanical damage index is one of performance parameters of a potato planter. External mechanical damage is a visible injury without cutting the tuber. The external mechanical damage index is determined and classified with different formulas and statements in the UK, Holland and Germany (McRae 1985). In addition, several workers have published methods of assessing the damage sustained by potatoes. However, damage index described by Robertson (1970) is used as a useful measure to compare the scale of external damage for crops of different cultivars or from different sites.

The objective of the current study was to evaluate effect of different tuber sizes and shapes, and ground speeds on external mechanical damage index and the uniformity of seed spacing of the full automatic planter's planting metering mechanism.

2. Material and Methods

Full automatic potato planter with two rows was used in the experiments (Figure 1). The main frame is supported by two wheels. The hopper of the potato planter is placed above the main frame. There are two planting metering mechanisms under the hopper. The driving wheels do not only carry most of the weight of the potato planter, but also drive the planting metering mechanism.

The planting metering mechanism consists of 14 pieces of cups and hold pins (Figure 2) attached to the circumference of a vertical disc (Figure 3). The hold pins and the cups mounted on the vertical disc constantly rotate with the vertical disc.



Figure 1- Potato planter used in experiment

Şekil 1- Denemede kullanılan patates dikim makinası

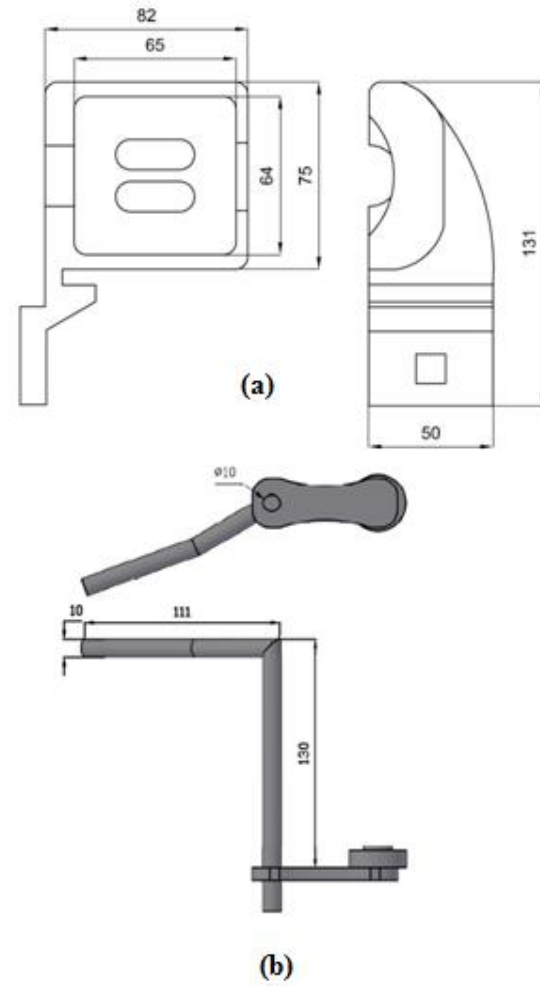

Figure 2- a, cup; b, hold pin

Şekil 2- a, Kepçe; b, tutucu çubuk

The hold pins are opened by the mechanism which is expressed as the pin-position cam. The pin-position cam is fixed. While the cup and the hold pin rotate, the roller on the hold pin hits the pin-position cam, and the hold pin is opened. Then, the cup passes through the tubers. Meanwhile, the planting mechanism selects a seed piece from the seed hopper. Then, hold pin moves onto the cup with the effect of a helical spring after the vertical disc rotates 170° degrees, and the potato seed is compressed by the hold pin and cup. After the cup rotates 190° degrees, the hold pin is opened by the pin-position cam, and potato seed drops into the furrow. This process repeats continuously. There is one planting metering mechanism for each row.

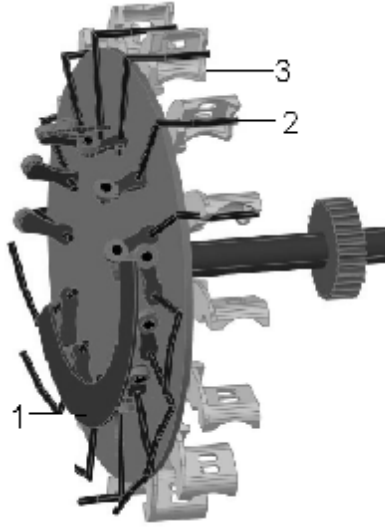

Figure 3- Planting metering mechanism: 1, hold pin-position cam; 2,hold pin; 3,cup

Şekil 3- Tohum dağıtma düzeni: 1, tutucu pinleri açma düzeneği; 2, tutucu çubuk; 3, kepçe

Agria and Marfona which are cultivar (cv.) of seed potatoes were used in the experiments. The seed potatoes were stored in the warehouse at low temperatures for five months after harvest. Potato seeds between 25 and 45 mm created one group. Potato seeds between 45 and 65 mm created the other group. This grouping was done by considering the regulation on certification and marketing of potato seeds published by Variety Registration and Seed Certification Centre of Turkey. Some physical properties such as shape factor, sphericity and mass of tuber were determined. Fifty tubers were randomly selected and their dimensions were measured by vernier calipers with an accuracy of 0.05 mm. Shape factor (Sf) was determined as (Buitenwerf et al 2006):

$$S_f = \frac{a^2}{bc} \times 100\% \quad (1)$$

a, b and c were determined by measuring the dimensions of the principle axes (Mohsenin 1986). Where a, b and c is the length, width and height of the tuber, respectively. There is a relation of $c < b < a$ between dimensions. Sphericity (Sp) and geometric

mean diameter (Dp) were determined as (Mohsenin 1986)

$$S_p = \frac{(abc)^{1/3}}{a} \times 100\% \quad (2)$$

$$D_p = (abc)^{1/3} \quad (3)$$

Some physical properties of the two varieties of potato used in this study are given in Table 1. The angular speeds were determined by taking into consideration the ground speeds (3.5, 5.4 and 7.3 km h⁻¹) of the potato planter. The angular speeds of the vertical disc were calculated as 1.56, 2.39 and 3.22 rad s⁻¹, respectively for these ground speeds. The feeding rates for these angular speeds were 207, 319 and 431 potatoes min⁻¹, respectively. In order to obtain these angular speeds, a three-phase induction motor driving sprocket on the axle of the vertical disc with a roller chain was used.

An AC speed control unit was used to change the rpm of the three-phase induction motor. The speeds were measured by a contact type digital tachometer. A laser measurement system was used to measure the time interval between consecutive tubers. The laser measurement system has an accuracy of 0.01 s. The laser measurement system consists of a laser pointer, a light dependent resistor (LDR), a software written using Matlab, a sound card and a computer (Figure 4).

The laser measurement system was placed under the planting metering mechanism (Figure 5). Potato passed through the pipe cut laser light so a change of voltage on the LDR occurred.

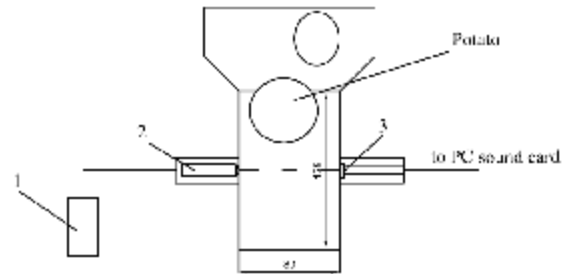

Figure 4- Laser measurement system: 1, DC power supply; 2, laser pointer; 3, LDR

Şekil 4- Lazer ölçüm sistemi: 1, DC güç kaynağı; 2, lazer pointer; 3, LDR

Table 1- Some physical properties of Marfona and Agria.*Çizelge 1- Marfona ve Agria'nın bazı fiziksel özellikleri*

	Marfona		Agria	
	<45 mm	>45 mm	<45 mm	>45 mm
a (mm)	48.8±4.5	66.3±5.9	53.4±5.5	76.1±7.3
b (mm)	40.7±1.7	52.8±4.0	38.4±4.2	50.3±6.5
c (mm)	36.9±2.8	45.5±3.5	34.7±3.5	66.0±5.2
D _p (mm)	41.8±2.0	54.1±3.2	41.3±2.4	55.8±3.1
Mass (g)	43.18±5.88	92.75±15.51	44.65±9.24	108.51±17.75
S _f	160.23±30.07	185.52±32.34	220.58±55.09	259.31±64.75
S _p	86±5.00	82±5.00	78±7.00	74±6.00

All values are presented as mean ± standard deviation

a, b and c was the dimensions of the principle axes

D_p: mean diameterS_f: Shape factorS_p: Sphericity

The change of voltage was determined with the help of a PC sound card, and the time interval between two voltage peaks was measured with the software.

Standard deviation of the time interval between consecutive tubers was used as a measure of plant spacing accuracy. The coefficients of variation (CV%) of plant spacing were considered the most important measure of performance of the potato planter. CV% values are changed by skips and doubles. Therefore, to

understand why CV% values are high or low, skips and doubles should be determined because skips and doubles are important indicators that determine the performance of potato planters. A miss or skip is defined as a gap equal to or greater than twice the intended center-to-center plant distance. A double was recorded when the space between adjacent seed pieces (center-to-center) was 0.07 m or less (Misener 1982; Zoraki & Acar 2000).

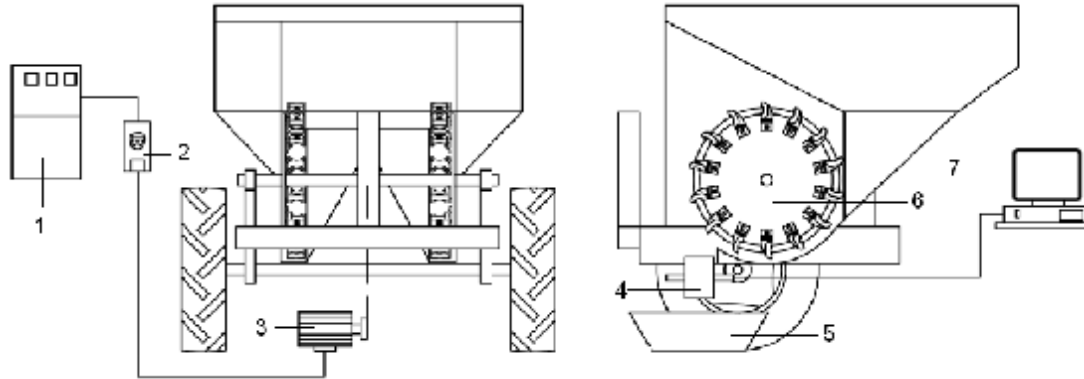

Figure 5- Laboratory test rig; 1, voltage regulator; 2, AC speed control unit; 3, induction motor; 4, laser measurement system; 5, plastic bowl; 6, planting metering mechanism; 7, personal computer

Şekil 5- Laboratuvar test düzeni; 1, voltaj regülâtörü; 2, AC hız kontrol ünitesi; 3, asenkron motor; 4, lazer ölçüm sistemi; 5, plastik toplama kabı; 6, tohum dağıtma düzeni; 7, kişisel bilgisayar

of the vertical discs was used in this arrangement. The seed potatoes were used only once in experiment.

Skips, doubles and CV% were calculated by the software. The experiment was laid out as a factorial arrangement consisting of two levels of seed potato cultivars, two levels of potato sizes, and three angular speed levels of vertical disc with three repetitions. For each repetition, the vertical disc was rotated 10 times. Potatoes that passed through the laser measurement system were dropped into soft plastic bowl. Only one

of the vertical discs was used in this arrangement. The seed potatoes were used only once in experiment.

To determine the external mechanical damage of tubers, 40 tubers were taken randomly from within plastic bowl at the end of every repetition. Then, to make external mechanical damage assessments, the tubers were divided into four categories; 1: undamaged, 2: scuffed, skin only broken but no flesh damage or slightly damage, 3: peeler, flesh damage to a depth not

greater than 2 mm, 4: severe, flesh damage deeper than 2 mm (Robertson 1970; McGechan 1980; McGechan 1981; Maine & Caligari 1988; Misener et al 1988; Altuntas 2001; BPC 2011). The weight of the tubers in each category was recorded. Then, external mechanical damage index was calculated based on the percentage of tubers in each category multiplied by 0, 1, 3, and 7, respectively. According to Robertson (1970), McGechan (1981) and BPC (2011) the potato external mechanical damage index was calculated as follows:

$$EMDI = \left(\frac{A}{E} \times 0\right) + \left(\frac{B}{E} \times 1\right) + \left(\frac{C}{E} \times 3\right) + \left(\frac{D}{E} \times 7\right) \quad (4)$$

Where EMDI is the external mechanical damage index, A is the weight of undamaged tubers, B is the weight of scuffed tubers, C is the weight of peeler tubers, D is the weight of severe tubers, and E is the weight of total tubers

3. Results and Discussion

ANOVA results belonging to the variation of coefficient of plant spacing, skips, doubles and external mechanical damage index of tuber are presented in Table 2. According to results of ANOVA, uniformity of plant spacing was significantly affected by all three experimental factors: the variety, the size and the angular speed, and size x angular speed (S x A) two-way interactions. The skips were significantly affected by the variety and the size, and size x angular speed (S x A) two-way interactions. All three experimental factors and variety x size (V x S) two-way interactions on the doubles had a significant influence. External mechanical damage index of tuber was significantly affected by all three experimental factors and variety x size x angular speed (V x S x A) three-way interactions. The relative effects of potato varieties, potato sizes and angular speeds on planter performance were summarized in Table 3.

Table 2- The variance analysis of in-row spacing uniformity, skips, doubles, and external mechanical damage index values

Çizelge 2- Stra üzeri dağılım düzgünlüğü, boşluk, ikizleme ve zedelenme indeks değerlerinin varyans analizi

Variation Sources	df	In-row spacing uniformity (CV%)		Skips, %		Doubles, %		External mechanical damage index	
		MSS	P	MSS	P	MSS	P	MSS	P
Variety (V)	1	23.73	0.015 ^[b]	7.50	0.000 ^[a]	35.43	0.000 ^[a]	1.01	0.000 ^[a]
Size (S)	1	81.40	0.000 ^[a]	28.70	0.000 ^[a]	119.96	0.000 ^[a]	1.73	0.000 ^[a]
Angular speed (A)	2	38.36	0.000 ^[a]	2.14	0.018 ^[b]	7.75	0.000 ^[a]	1.14	0.000 ^[a]
Replication	2	1.85	0.587	0.61	0.271	0.35	0.399	0.00	0.599
V*S	1	9.08	0.116	0.69	0.222	2.78	0.012 ^[b]	0.08	0.000 ^[a]
V*A	2	0.99	0.750	0.27	0.551	0.18	0.614	0.00	0.507
S*A	2	13.82	0.031 ^[b]	5.65	0.000 ^[a]	1.12	0.069	0.00	0.287
V*S*A	2	0.60	0.840	0.10	0.800	0.35	0.399	0.02	0.012 ^[b]
Residual	22	3.39		0.44		0.37		0.00	
Total	35								

^[a] Indicates significance at 1% level of probability

^[b] Indicates significance at 5% level of probability

The performance of the potato planter was significantly affected by the potato shape, potato size and angular speeds of the vertical disc. The effect of potato varieties on CV% was statistically significant ($P < 0.05$). The highest mean value of CV% was found to be 25.58% for Marfona. The lowest mean value of CV% was found as 23.96% for Agria. There was 6.8% difference between the CV% values of Agria and Marfona. It was observed that there was a contrary correlation between shape factor and CV% as the shape factor increased; the accuracy of tuber spacing became better. It may be said that oblong tubers held by hold pins were better than round tubers, and it is possible that oblong tubers deposited in cups better than round tubers. Similarly, Buitenverf et al (2006) stated that the

standard deviation of the balls with a shape factor of 100 was higher than the oblong tubers.

Potato size was found to be an important parameter affecting the uniformity of tuber spacing. The highest mean value of CV% was found to be 26.27% for small potatoes seed pieces. The lowest mean value of CV% was found to be 23.26% for big potatoes seed pieces. As the tuber size increased, the accuracy of tuber spacing increased. Possibly, it was more difficult to capture small potatoes seed pieces than to capture large potatoes seed pieces by hold pins and cups. Similarly, Misener (1982) determined in a field experiment conducted to estimate the effect of seed piece size and type on different potato planters that as the tuber size increased, the accuracy of tuber spacing increased.

Table 3- Effects of varieties, sizes and angular speeds on in-row spacing uniformity, skips, doubles, and external mechanical damage index values.

Çizelge 3- Sıra üzeri dağılım düzgünlüğü, boşluk, ikizleme ve yaralanma indeks değerleri üzerine çeşidin, yumru büyüklüğünün ve hızın etkisi.

Treatments		Variation of coefficient (CV%)	Skips, %	Doubles, %	External mechanical damage index
Potato varieties	Marfona	25.58 a	2.90 b	4.41 a	0.85 b
	Agria	23.96 b	3.81 a	2.42 b	1.18 a
Potato Sizes (mm)	45>	26.27 a	2.46 b	5.24 a	0.80 b
	45<	23.26 b	4.25 a	1.59 b	1.23 a
Angular speeds (rad s ⁻¹)	1.56	23.42 b ^[a]	3.27 ab	2.62 c	0.72 c
	2.39	24.09 b	2.80 b	3.39 b	0.99 b
	3.22	26.80 a	3.81 a	4.23 a	1.34 a
	LSD	1.56	0.56	0.52	0.047

^[a]Means in a single column without the same letter are different at the 5% level using the LSD test.

According to analysis, the accuracy of tuber spacing, CV%, was significantly affected by angular speeds of the vertical disc. The highest mean value of CV% was obtained as 26.80% for 3.22 rad s⁻¹. The lowest mean value of CV% was obtained as 23.42% for 1.56 rad s⁻¹. However, the difference between 1.56 and 2.39 rad s⁻¹ was statistically insignificant. As the angular speed increased, the accuracy of tuber spacing became worse. These results agreed with the results reported by Altuntas (2005). In addition, some researchers stated that as the angular speed increased, the accuracy of tuber spacing became better (Buitenwerf et al 2006; Siczka et al 1986). For the accuracy of a different potato planter in same research, Siczka et al (1986) stated that as the angular speed increased, the accuracy of tuber spacing became worse. Essentially, what is desired from a potato planter is protection the accuracy of tuber spacing at all ground speeds. In experiment, it was observed that there was a 14.5% difference between the highest CV% value and the lowest CV% value of angular speed of the vertical disc. Planting accuracy ranged generally from 20% to 80% in many farm researches (Entz & LaCroix 1983; Siczka et al 1986; Misener 1982). Generally, it may be said that tuber spacing accuracy of the planter was suitable at all angular speeds of the vertical disc. There was an interaction of S x A on CV% (Figure 6). It was observed that it was hard to catch both sizes of tubers in the cups because of the increasing angular speed of the vertical disc.

The effect of potato variety on skips and doubles was statistically significant ($P < 0.01$). It was observed that there was an inverse correlation between skips and

doubles. As the percentage of skips increased, the percentage of doubles decreased.

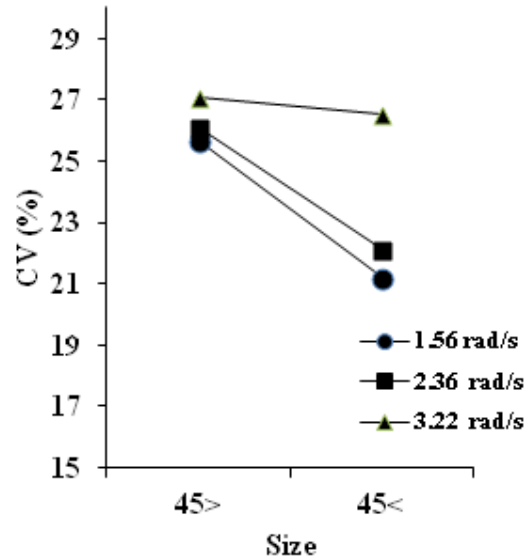

Figure 6- Plot of S X A interaction on CV%

Şekil 6- S X A interaksyonunun % CV grafiği

Probably, that was why the physical properties of Marfona were different than those of Agria. The highest mean percentage of skips was found as 3.81% for Agria. The lowest mean percentage of skips was found to be 2.90% for Marfona. The highest mean percentage of doubles was found to be 4.41% for Marfona. The lowest mean percentage of doubles was

found to be 2.42% for Agria. The effect of small and large tubers on the percentage of skips and doubles was significant. The highest mean percentage of skips and doubles were found to be 4.25% and 5.24% for large potatoes seed pieces and small potato seed pieces, respectively. The lowest mean percentage of skips and doubles were found to be 2.46% and 1.59% for small potato seed pieces and large potato seed pieces, respectively. Missener (1982) & Altuntas et al (2004) reported that as the size of tubers increased, the number of skips produced by the tuber unit planter increased. In particular, the percentage of doubles obtained from small tubers was higher than those obtained from large tubers because two or more small tubers frequently logged in one seed cup. These results were compared with those found by Missener (1982) who measured skips and doubles as having a range from 7.7% to 7.8% and from 14.1% to 23.7, respectively for <40 mm of tubers, and as having a range from 4.1 to 9.2 and from 6.6 to 16.5, respectively for > 40 mm of tubers. Skips and doubles were significantly affected by angular

speeds of the vertical disc. The highest mean percentage of skips was obtained as 3.81% for 3.22 rad s⁻¹. The lowest mean percentage of skips was obtained as 2.80% for 2.39 rad s⁻¹. The highest mean percentage of doubles was obtained as 4.23% for 3.22 rad s⁻¹. The lowest mean percentage of doubles was obtained as 2.62% for 1.56 rad s⁻¹. As the angular speed of the vertical disc increased and percentage of skips and doubles increased. S x A interaction on skips and V x S interaction on doubles were significant. Plots of these interactions are showed in Figure 7a&b. It was observed that it was hard for the large tubers to be caught by the cups because of the increasing angular speed of the vertical disc. That was the reason for interaction (S x A) (Figure 7 a). The difference between the values of doubles obtained from Marfona and Agria for >45 mm of tubers was lower than those obtained from Marfona and Agria for <45 mm of tubers (Figure 7b). This effect may be explained as being due to having high sphericity of Marfona.

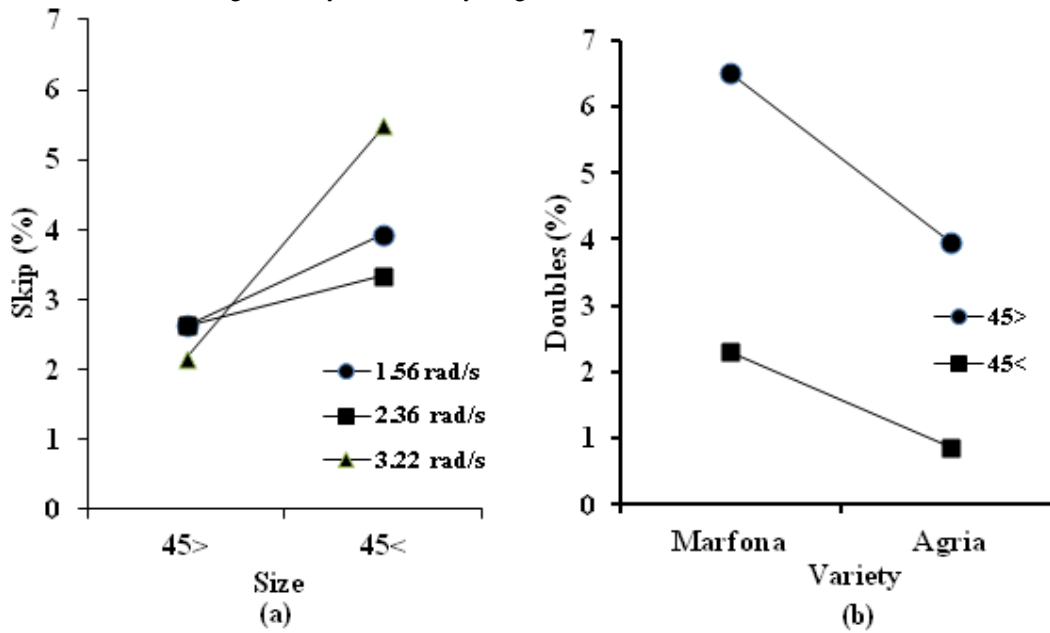

Figure 7- a, Plots of S X A interaction on skips; b, V X S, interaction on doubles

Şekil 7-a, S X A interaksiyonunun boşluk grafiği; b, V X S interaksiyonunun ikizleme grafiği

The results of analysis indicated that the effects of the angular speeds of the vertical disc, potato varieties and potato sizes on external mechanical damage index were significant ($P<0.01$). The external mechanical damage index increased as the angular speed of the vertical disc increased. The highest mean value of the external mechanical damage index was obtained as 1.34 for 3.22 rad s⁻¹ (Table 3.). The lowest mean value of the

external mechanical damage index was obtained as 0.72 for 1.56 rad s⁻¹. The highest mean value of external mechanical damage index was obtained as 1.18 for Agria. The lowest mean value of the external mechanical damage index was obtained as 0.85 for Marfona. It was observed that Agria was more sensitive than Marfona. There was a significantly different between potato sizes on the external mechanical

damage index. The external mechanical damage index value obtained from the large tubers was higher than that of small tubers. The highest mean value of the damage index was obtained as 1.23 for large tubers. The lowest mean value of the damage index was obtained as 0.8 for small tubers. The large tubers were more sensitive than the small tubers. According to results of ANOVA, V x S and V x S x A interaction on the external mechanical damage index were significant. Plots of these interactions are showed in Figure 7 a&b. The results were showed that the external mechanical damage index values obtained from >45 mm tubers of

Agria was higher than those obtained from <45 mm tubers of Agria. This was reason of V x S interaction (Figure 8 a). For Marfona and Agria, there was little interaction with the lines being close to parallel with a very slight tendency for the effect of size (Figure 8 b). The effect on the external mechanical damage index was determined to be bigger for an angular speed of 3.22 rad s^{-1} than for the other angular speeds in >45 mm of seed potato of Marfona, and higher than expected for an angular speed of 1.56 rad s^{-1} in >45 mm of seed potato of Agria.

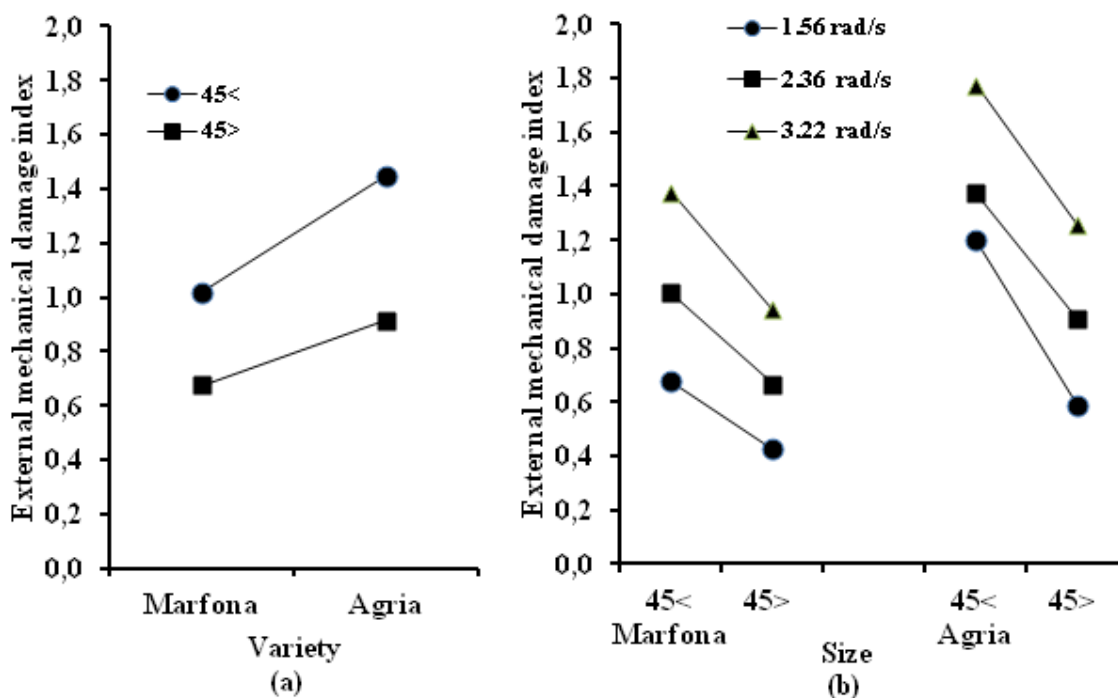

Figure 8- a, Plots of V X S; b, V X S X A is interaction on external mechanical damage index
Şekil 8- a, V X S interaksiyonunun; b, V X S X A interaksiyonunun yumru yaralanma indeksi grafiği

4. Conclusions

The laboratory test showed that the angular speed of the vertical disc, potato varieties and potato sizes affected the performance of the potato planter. It was found that CV% value disturbed as the angular speed increased. Although the shape factor of Agria was larger than Marfona, the CV% value of Agria was smaller than Marfona. It was observed that the CV% value obtained from small tubers was higher than those obtained from large tubers. As the angular speed increased, the percentage of skips and doubles increased generally. The percentage of skips in Agria was higher than that of Marfona. However, the

percentage of doubles in Agria was smaller than that of Marfona. There was a marked increase in the percentage of doubles obtained from small tubers because two or more tubers frequently logged in one seed cup. However, the percentage of skips obtained from the small tubers was smaller than that obtained from large tubers. The effect of treatments on the external mechanical damage index was significant. It was found that the external mechanical damage index increased as the angular speed increased. The external mechanical damage index of Agria was higher than that of Marfona because of the shape factor of Agria and because the large tubers in the external mechanical

damage index were the more sensitive than small tubers.

Acknowledgements

The authors are grateful for financial support from the Research Fund of Atatürk University, Erzurum, Turkey, and for helps in the preparation and sending of the potato planter to Kenan Ertugrul Tarım Makineleri, Özel Organize Sanayi Bölgesi, Nevşehir, Turkey

References

- Altuntas E (2001). Determination of the effects on some soil properties and tuber damage, harvest losses and harvesting efficiency of the forward speeds at semi-automatic potato harvester. *Tarım Bilimleri Dergisi-Journal of Agricultural Sciences* **7**(2): 47-53
- Altuntas E, Taşer Ö F & Tekelioğlu O (2004). Determination of the effects of the tuber size and different vibration positions of the planting unit on seed tuber distribution pattern with a full automatic potato planter. *Tarım Bilimleri Dergisi-Journal of Agricultural Sciences* **10**(1): 104-110
- Altuntas E (2005). The effects of some operational parameters on potato planter's performance. *Agricultural Mechanization in Asia, Africa, and Latin America* **36**(2): 71-74
- BPC (British Potato Council) (2011). How to complete a damage and bruising assessment? Available at: <http://www.potato.org.uk>
- Buitenwerf H, Hoogmoed W B, Lerink P & Müller J (2006). Assessment of the behavior of potatoes in a cup-belt planter. *Biosystems Engineering* **95**(1): 35-41
- Bussan A J, Mitchell P D, Copas M E & Drilias M J (2007). Evaluation of the effect of density on potato yield and tuber size distribution. *Crop Sciences Society of America* **47**: 2462-2472
- Creamer N G, Crozier C R, & Cubeta M A (1999). Influence of seed piece spacing and population on yield, internal quality, and economic performance of Atlantic, Superior, and Snowden potato varieties in Eastern North Carolina. *American Journal of Potato Research* **76**: 257-261
- Entz M H & LaCroix L J (1984). The effect of in-row spacing and seed type on the yield and quality of a potato cultivar. *American Potato Journal* **61**: 93-105
- Gulluoglu L & Arioglu H (2009). Effects of seed size and in-row spacing on growth and yield of early potato in a mediterranean-type environment in Turkey. *African Journal of Agricultural Research* **4**(5): 535-541
- Halderson J L, Ojala J C, Harding G W & Musselman E V (1992). Influence of seed placement on Russet Burbank potato yield and grade. *American Potato Journal* **69**: 31-38
- Hirst J M, Hide G A, Stedman O J & Griffith R L (1973). Yield compensation in gappy potato crops and methods to measure effects of fungi pathogenic on seed tubers. *Annals of Applied Biology* **73**:143-150
- Hussain A & Gillani M G (1985). Potato as staple food. In: *Potato in Pakistan: the present situation of research production and marketing programme, Pakistan Agricultural Research Council*,191-195, 2-4 Apr, Islamabad, Pakistan
- James W C, Lawrence C H & Shih C S (1973). Yield losses due to missing plants in potato crops. *American Potato Journal* **50**:345-352
- Klassen J (1974). Potato planter speeds-how do they affect stand and production. In: *Proceedings of the 13th Annual Washington State Potato Conference and Trade Fair*, 71-74, Moses Lake, Washington, USA.
- Klassen J (1975). Planter performance study. In: *Proceedings of the 14th Annual Washington State Potato Conference and Trade Fair*, 43-47, Moses Lake, Washington, USA
- Love S L & Thompson-Johns A (1999). Seed piece spacing influences yield, tuber size distribution, stem and tuber density, and net returns of three processing potato cultivars. *Hortscience* **34**:629-633
- Maine M J & Caligari P D S (1988). Assessments of the resistance of potato cultivars and breeder's clones to external mechanical damage. *Tarım Bilimleri Dergisi-Journal of Agricultural Science* **110**: 527-530
- McGechan M B (1980). An investigation into the damage sustained by different varieties of potatoes during riddling to remove soil. *Journal of Agricultural Engineering Research* **25**:345-353
- McGechan M B (1981). A comparison of some studies of damage susceptibility of different potato varieties. *Journal of Agricultural Engineering Research* **26**:161-170
- McPhee J E, Beattie B M, Corkrey R & Fennell J F M (1996). Spacing uniformity-yield effects and in-field measurement. *American Potato Journal* **73**:167-171
- McRae D C (1985). A review of developments in potato handling and grading. *Journal of Agricultural Engineering Research* **31**:115-138
- Misener G C (1982). Potato planters - uniformity of spacing. *Transactions of the ASAE* **25**(6): 1504-1505
- Misener G C & McLeod C D (1988). A plot planter for potatoes. *American Potato Journal* **65**: 289- 293
- Mohsenin N N (1986). Physical Properties of Plant and Animal Materials. Gordon and Breach Science Publishers, New York, NY
- Potato (2008). The potato of cultivation. Available at: <http://www.potato2008.org>
- Pavek M J & Thornton R E (2003). Poor planter performance: what's it costing the average Washington potato grower? In: *Proceedings of the 42th Annual Washington State Potato Conference and Trade Fair*, 13-21, Moses Lake, Washington, USA
- Rex B L, Russell W A & H R Wolfe (1987). The effect of spacing of seed pieces on yield, quality and economic value for processing of shepody potatoes in Manitoba. *American Potato Journal* **64**:177-189
- Roberston I M (1970). Assessment of damage in potato tubers. Dept. Note SIN/60 Scottish Institute of Agricultural Engineering, Penicuik, Scotland
- Rupp J N & Thornton R E (1992). Seed placement and plant stand - is it worth worrying about? Proceeding. 31th Annual Washington State Potato Conference and Trade Fair, Moses Lake, WA. pp. 167-181
- Schotzko R T, Hyde G M & Thornton R E (1983). The dollars and cents of the 1982 potato seed size and spacing

- survey. In: *Proceedings of the 22th Annual Washington State Potato Conference and Trade Fair*, 23-29, Moses Lake, Washington, USA
- Seyedbagheri M (2006). On-farm evaluation of potato planter performance. Presented at the Idaho Potato Conference on January 18
- Sieczka J B, Ewing E E & Markwardt E D (1986). Potato Planter performance and effects of non-uniform spacing. *American Potato Journal* **63**: 25-37
- Thornton R E, Schotzko T & Hyde G (1983). Some other factors in obtaining good plant stands. In: *Proceedings of the 22th Annual Washington State Potato Conference and Trade Fair*, 93-101, Moses Lake, Washington, USA
- Zoraki M & Acar A I (2000). Optimum design of cup shape used in full automatic potato planter. *Tarım Bilimleri Dergisi- Journal of Agricultural Science* **6**(4):135-140